



THE COMPLETE MULTI-ENGINE PILOT



FIFTH EDITION

Bob Gardner

THE COMPLETE **MULTI-ENGINE PILOT**

FIFTH EDITION

Bob Gardner



AVIATION SUPPLIES & ACADEMICS, INC.
NEWCASTLE, WASHINGTON

The Complete Multi-Engine Pilot

Fifth Edition

by Bob Gardner

Aviation Supplies & Academics, Inc.
7005 132nd Place SE
Newcastle, Washington 98059
asa@asa2fly.com | 425-235-1500 | asa2fly.com

Copyright © 2022 Aviation Supplies & Academics, Inc.

See the ASA website at asa2fly.com for updates due to FAA regulation changes that may affect this book.

All Rights Reserved. No part of this publication may be reproduced, stored in a retrieval system, or transmitted in any form or by any means, electronic, mechanical, photocopy, recording, or otherwise, without the prior written permission of the copyright holder. While every precaution has been taken in the preparation of this book, the publisher and Bob Gardner assume no responsibility for damages resulting from the use of the information contained herein.

None of the material in this book supersedes any operational documents or procedures issued by the Federal Aviation Administration, aircraft and avionics manufacturers, flight schools, or the operators of aircraft.

ASA-MPT-5-PD

ISBN 978-1-64425-198-0

Additional formats available:

Softcover ISBN 978-1-64425-195-9
eBook EPUB ISBN 978-1-64425-197-3
eBundle ISBN 978-1-64425-196-6 (print + eBook PDF download code)

Cover photos: Courtesy of Tecnam Aircraft.

Photo and illustration credits: Fig. 2-1, photo courtesy Chuck Pepka; Fig. 2-4 (bottom), courtesy Diamond Aircraft; Fig. 2-6, courtesy Avco Lycoming Flyer; Figs. 2-9, 2-14, 3-1, 3-4-3-10, 3-15, 3-17-3-19, 3-21-3-24, 5-1, 5-2, 6-1, 7-1, courtesy Beech Aircraft Corporation; Fig. 5-7, Jim Larson; Figs. 8-1-8-4 from FAA-H-8083-3C; *Note:* All illustrations from the Beechcraft Duchess Manual are for educational purposes only and are not to be used for the operation of any aircraft.

Library of Congress Cataloging-in-Publication Data:

Names: Gardner, Bob, 1928–2021, author.

Title: The complete multi-engine pilot / Bob Gardner.

Other titles: Multi-engine pilot | Complete pilot series.

Description: Fifth edition. | Newcastle, Washington : Aviation Supplies & Academics, Inc., [2022] | Series: The Complete pilot series | Includes index.

Identifiers: LCCN 2021054467 (print) | LCCN 2021054468 (ebook) | ISBN 9781644251959 (trade paperback) | ISBN 9781644251973 (epub) | ISBN 9781644251980 (pdf) | ISBN 9781644251966 (eBundle, print+eBook PDF download code)

Subjects: LCSH: Multiengine flying. | Airplanes—Piloting. | Flight training—United States.

Classification: LCC TL711.T85 G37 2022 (print) | LCC TL711.T85 (ebook) | DDC 629.132/520973—dc23/eng/20211123

LC record available at <https://lccn.loc.gov/2021054467>

LC ebook record available at <https://lccn.loc.gov/2021054468>

Contents

Acknowledgments and About the Author	vi
Foreword	vii
Introduction to Twins	viii
1 The Concept of Multi-Engine Flying	1
Why Two Engines?	1
Beginning Your Multi-Engine Training	3
What Happens When an Engine Fails	3
Multi-Engine Aerodynamics	3
Centerline Thrust	6
Review Questions	7
2 Multi-Engine Airplane Systems	9
Propeller Feathering	9
Accumulators	11
Air Starts	12
Propeller Synchronizers	12
Heat Consciousness	12
A Review of Fuel Injection	14
Diesel Engines	15
Fuel Systems	15
Electrical Systems	16
Turbocharging	20
Landing Gear Extension Systems	23
Environmental System	24
Vacuum System	25
Ice Protection System	26
Emergency Exit System	28
Autopilots	28
Flight Directors	28
Electric Trim	29
Oxygen	29
Jets	30
Summary	30
Review Questions	31

3	Planning and Performance	33
	Weight and Balance Calculations	33
	Zero-Fuel Weight.....	34
	Lateral Balance	38
	Performance Planning	38
	Minimum Controllable Airspeed	40
	Minimum Controllable Airspeed on the Ground	42
	Minimum Safe Single-Engine Speed	42
	Best Angle and Best Rate-of-Climb Speeds.....	42
	Landing Gear Extension and Operating Speeds.....	43
	Engine-Out Climb Speeds.....	43
	Maneuvering Speed, Normal Operating Speed, and Never-Exceed Speed	44
	More Important V-Speeds.....	44
	Performance Airspeeds Versus Weight	44
	Using Performance Charts	44
	Review Questions	52
4	Preflight Preparation	53
	The Preflight Inspection.....	53
	Taxiing.....	53
	Student and Instructor Relationship.....	54
	Passenger Briefing.....	54
	Preflight Runup.....	54
	Last Thoughts.....	54
	Review Questions	55
5	Takeoff and Departure	57
	Engine Failure on Takeoff	57
	Calculating Climb Rates Before Takeoff	59
	The Takeoff Roll.....	60
	Engine Fails!	61
	Cleaning Up the Airplane	62
	“Abnormal” Takeoffs	63
	Review Questions	65
6	Cruising Flight	67
	The Cruise Checklist.....	67
	Service and Absolute Ceilings	69
	Engine Failure During Cruise Flight	70
	Drift Down	71
	Review Questions	72
7	Descent, Approach, and Landing	73
	Descent Planning.....	73
	Beginning the Descent.....	73
	Leveling Off.....	74
	On Final	74
	Landing Distance.....	75
	Getting It Stopped.....	75

Single-Engine Approach and Landing.....	76
Landing with a Propeller Feathered.....	77
Review Questions	78
8 Energy Management	79
Importance	79
Basics of an Airplane Energy System	79
Managing Energy.....	79
Roles of the Flight Controls.....	80
Basic Rules of Energy Control.....	81
Managing Risks and Errors	81
Review Questions	83
9 Preparing for the Checkride	85
Certificates and Documents.....	85
Airplane Systems	85
Normal Procedures.....	86
Determining Performance and Flight Planning.....	86
Minimum Equipment List.....	86
Flight Principles: Engine Inoperative.....	86
Ground Operations.....	87
Normal and Crosswind Takeoffs and Climbs.....	87
Maximum Performance Takeoffs and Climbs.....	88
Instrument Flight.....	88
Slow Flight and Stalls	88
Spins.....	88
Steep Turns.....	89
Drag Demonstration.....	89
V _{MC} Demonstration	89
System and Equipment Malfunctions.....	90
Balked Landing.....	92
Normal and Crosswind Approaches and Landings.....	92
Maximum Performance Approach and Landing.....	92
Appendix A: Multi-Engine Rating Syllabus.....	93
Appendix B: Written Exam for Multi-Engine Checkout.....	103
Appendix C: Answers to Review Questions.....	109
Appendix D: Further Study in FAA Source Material.....	113
Glossary.....	183
Index	187

Introduction to Twins

Art Blanster's six-passenger single-engine airplane is sleek, fast, and equipped with the latest in navigation equipment, but it is uncomfortably close to its maximum gross takeoff weight when he loads it with his business associates and the equipment they need to make a sales demonstration in a distant city. A multi-engine airplane will give Art the load-carrying capability that he needs. Adding "Multi-Engine Land" to his certificate is a business necessity.

Paula Forsham's flying club has six singles and a twin, and she is checked out in every one of the single-engine airplanes. Six months ago, a vacuum pump failure in one of them resulted in a descent through clouds using needle, ball, and airspeed, and just last week a broken alternator belt caused a total electrical failure. Paula is aware that a twin's redundant vacuum and electrical systems will tip the odds in her favor.

Pat Manley is 21 and has already logged 1,400 hours in single-engine airplanes as an instructor and charter pilot. He wants to put a multi-engine Airline Transport Pilot certificate in his wallet when he turns 23, and he knows that the more twin time he has in his log, the better his chances with a commuter or major airline will be. For Pat, getting a twin rating is a smart career move.

Each of these pilots accepts the fact that getting a multi-engine rating will involve additional costs, but they all feel the advantages outweigh the cost factor. Each pilot will rationalize the decision to upgrade in his or her own way, but there is no denying that having Multi-Engine Land added to a pilot's certificate provides the extra pride of accomplishment that goes with stepping up to a higher skill level. Paula, Pat, and Art are ready to take on a new challenge—are you?

MULTI-ENGINE TRAINING

The FAA does not require you to log a minimum number of hours of instruction before the multi-engine checkride. The flight check is a demonstration of proficiency, and your instructor will sign the recommendation form when he or she feels you are ready. During training, you will probably spend an hour or two doing airwork such as slow flight, approaches to stalls, and steep turns, to develop a sense of how an airplane with more of its mass off-center behaves. Pattern work will consist of normal takeoffs and landings as well as short- and soft-field takeoffs and landings. Then the emphasis will shift to emergencies, both at altitude and close to the surface.

You can hone some of the required skills in a good multi-engine simulator, at a considerable reduction in cost and total time. My definition of a "good" multi-engine aviation training device (FAA-speak for what light-plane folks call simulators) is one that replicates the changes in control pressures that occur when an engine fails—most pilot reactions to emergency situations are based on rudder pressure.

Although skill levels of pilots and instructors vary, figure that five hours is a questionable short course, and that twenty hours of airplane time is overkill. Ground-training device time will shorten the amount of airplane time required.

No FAA Knowledge Exam is required for the multi-engine rating, but you can expect to be grilled on your trainer's performance numbers and operational systems by your instructor, by the examiner who gives you the checkride, and by anyone from whom you rent a similar twin. Thorough knowledge of any multi-engine airplane's systems is required.

14 CFR 61.129(b)(4) has been changed to allow a pilot to log solo time (“performing the duties of pilot-in-command”) in a twin when the right seat is occupied by an appropriately rated instructor. This change was driven by the insurance industry, which would not provide coverage for a twin flown solo by a pilot not rated in the aircraft.

This is an outline of what you are getting into, as far as flying goes. Now let’s talk about this book.

Isn’t it true that almost all of your one-on-one education as a pilot took place before you received your Private Pilot certificate, when new information and experiences were a part of every flight lesson? Except for being checked out in different singles, have you had many opportunities to sit down with an instructor and go over how the aeronautical facts of life you learned as a student apply to larger, more powerful airplanes? As a multi-engine pilot, your safety and that of your passengers will depend on your full understanding of the aerodynamic laws that govern flight in a twin when one engine is not delivering power. This book is intended to serve as that one-on-one talk.

Yes, there are dual systems, but they offer more variables than you have been exposed to in single-engine airplanes. You need a thorough grasp of how these systems work, what they can do for you, and how they are affected by an engine failure. This book will dig more deeply into systems than did your basic texts.

What will the examiner look for on your checkride? To what new experiences will your multi-engine instructor expose you? What new elements of flight planning will a multi-engine airplane require? We’ll go through each of these subjects together, with the goal of making you a knowledgeable multi-engine pilot.

Other than having an extra engine, how does a twin differ from the airplanes you have been flying? We’ll discuss that first, with special attention to operating systems, then we will look into the planning considerations. From there, we will go into a normal takeoff and climb, cruise considerations, approach planning, and the landing. All-engine and engine-out procedures are discussed in each section. We’ll discuss the FAA Airman Certification Standards for the multi-engine rating and talk about how to prepare for each area of operation and task.

From the earliest hours of your private pilot training you were asked, “Where would you put it if the engine failed?” Your job was to find a suitable landing site within gliding distance, and you didn’t have to

fight to control the airplane on the way down. When one engine quits on a twin, however, control is your paramount concern. That is why your training—and this book—will concentrate heavily on what to do if an engine fails, why the failure causes control problems, and how following the correct procedures will make the airplane easier to control.

There will be review questions at the end of each chapter. They are meant for confirming your understanding, not for preparing for a Knowledge Exam.

THE MULTI-ENGINE INSTRUCTOR RATING

A flight instructor with a multi-engine rating on his or her pilot certificate can add a multi-engine rating to his or her flight instructor certificate by taking a checkride with an FAA operations inspector or designated examiner. No minimum training time is required, and there is no knowledge examination. However, the applicant must have logged at least 15 hours as pilot-in-command in the category and class of aircraft involved (multi-engine land or multi-engine sea).

Additionally, before training a pilot in a specific make and model of multi-engine airplane, an MEI must have logged 5 hours as pilot-in-command in that make and model. That is, if you get your MEI in a Duchess you must log 5 hours of Seneca II time before giving multi-engine instruction in a Seneca II. This is not a nit-picky requirement—manufacturers make changes in systems and procedures between models, and you cannot assume that what worked with twin A will work with twin B.

IMPORTANT V-SPEEDS AND DEFINITIONS

As you begin your multi-engine training, you will be introduced to many important performance V-speeds and their definitions unique to multi-engine airplanes. Many of these speeds are specific to one-engine-inoperative (OEI) operations. Below is a list of these important speeds and definitions that you will come across during your training. This list of V-speeds and the glossary in the back of book are good, quick references to look up the definition of a specific V-speed or term.

V_R Rotation speed—speed at which back pressure is applied to rotate the airplane to a takeoff attitude.

- V_{LOF} Lift-off speed—speed at which the airplane leaves the surface. (Note: Some manufacturers reference takeoff performance data to V_R , others to V_{LOF} .)
- V_X Best angle of climb speed—speed at which the airplane gains the greatest altitude for a given distance of forward travel.
- V_{XSE} Best angle of climb speed with OEI.
- V_Y Best rate of climb speed—speed at which the airplane gains the most altitude for a given unit of time.
- V_{YSE} Best rate of climb speed with OEI. Marked with a blue radial line on most airspeed indicators. Above the single-engine absolute ceiling, V_{YSE} yields the minimum rate of sink.
- V_{SSE} Safe, intentional OEI speed—originally known as safe single-engine speed. It is the minimum speed to intentionally render the critical engine inoperative.
- V_{REF} Reference landing speed—an airspeed used for final approach, which is normally 1.3 times V_{SO} , the stall speed in the landing configuration. The pilot may adjust the approach speed for winds and gusty conditions by using V_{REF} plus an additional number of units (e.g., $V_{REF} + 5$).
- V_{MC} Minimum control speed with the critical engine inoperative—defined in 14 CFR §23.2135(c) as the calibrated airspeed at which, following the sudden critical loss of thrust, it is possible to maintain control of the airplane. V_{MC} is typically marked with a red radial line on most airspeed indicators

Remember, specific V-speeds for the airplane you are flying can be found in the airplane flight manual (AFM) or pilot's operating handbook (POH) and can vary with aircraft weight, configuration, and atmospheric conditions.

The Concept of Multi-Engine Flying

Why does a multi-engine airplane need two engines? Because it won't fly on one, that's why. To expand on this statement, the significant factor is "pounds per horsepower," which relates to the amount of weight a given engine can haul into the air at sea level on a standard day. If you want to lift more pounds, you must either install a larger engine or add an engine, and there are practical limits as to just how big a single-engine can be for a given airframe. Big engines require lots of room and a plentiful source of cooling air, which translates into a large cowling with equally large frontal area. That, in turn, adds drag, and pretty soon you defeat the original purpose. Often, the best solution is a second engine.

WHY TWO ENGINES?

The Piper Seneca (Figure 1-1) is an excellent example of a manufacturer adding a second engine to an existing airframe. Its ancestor, the Cherokee Six, with a single 300-horsepower engine, is able to carry seven people and has capacious baggage compartments. The Seneca I (the original, non-turbocharged model) was a Cherokee Six airframe with two engines. It didn't offer much in the way of additional useful load, but it did provide two-engine safety. Other examples of singles that became twins when they grew up are the Twin Comanche and the Baron.

The gain that is achieved by adding an engine is in excess horsepower. Every airplane derives its ability to climb from excess horsepower; excess, that is, to the amount of power required to sustain level flight. You typically choose a cruise power setting which keeps power in reserve, ready for use when called upon, instead of pushing all of the levers full forward. Those



Figure 1-1. Piper Seneca II

extra horses would, if summoned to action, provide either greater level flight speed or climb capability. As you climb to higher altitudes, and the power output of the engines decreases, the ability to climb also decreases. When rate of climb has decreased to 100 feet per minute, the airplane has reached its service ceiling.

Figure 1-2 on the next page illustrates how total drag varies with airspeed. Its components are induced drag, which is greatest at low speed and diminishes as speed increases, and parasite drag, which is negligible at low speed but increases with the square of airspeed. The minimum total drag point (the bottom of the curve) is very close to the single-engine best rate-of-climb speed, which is achieved, in this illustration, at 40% power.

As you can see, there is plenty of excess power to the right of the minimum drag point as long as both engines are running. When the power of one engine is not available, however, only the power in the shaded portion of the graph is available. High density altitude

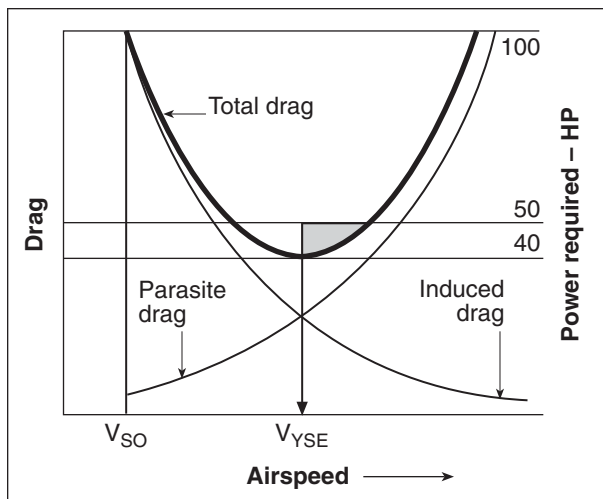

Figure 1-2. Drag vs. airspeed

or a “good” engine which, for one reason or another, is not putting out full rated power, will cause the shaded area to shrink.

During the first hour or so of multi-engine training, you and your instructor can perform an experiment that will prove how the excess horsepower pays off. Trim your aircraft to maintain level flight at its best rate-of-climb speed and record the power setting; then, without touching the throttle or trim wheel, pull back on the control yoke and wait. For a few moments, the kinetic energy of the airplane’s forward motion will allow it to climb—but it won’t last. Because the increased angle of attack adds to induced drag, the airspeed will slowly decrease and the airplane will begin to descend. After a few oscillations, it will stabilize at the original altitude. You have established the minimum power required to maintain altitude. Now go back to the original situation (trimmed for level flight at V_Y) and add power; the aircraft will climb as a result of power in excess of that required to sustain level flight. It should be apparent that if an engine fails, erasing one-half of the total power, there will be little excess power available for climbing.

To prove how the loss of excess power hurts performance, repeat your earlier experiment, but this time trim to maintain the single-engine best rate-of-climb speed (V_{YSE} , or the blue line on the airspeed indicator) in level flight. Pull one throttle back to zero thrust (about 12 inches of manifold pressure is a good approximation) and do whatever is necessary to the remaining engine to avoid losing altitude. You will find that the “good” engine is producing 75% power or more, and that pushing it up to maximum power may

result in a very modest rate of climb. The effect of the loss of power in excess of that necessary for level flight will be obvious. Indeed, depending on density altitude and weight, your airplane might not climb at all. File that away in your memory bank for later reference.

This is the concept of multi-engine flight—add a second engine, and as long as both are humming the same tune, you will have copious amounts of excess horsepower to convert into cruising speed or climb capability if temperature, pressure altitude, and weight are within reasonable limits. That’s the good news.

The bad news is that your multi-engine flight training will place disproportionate emphasis on engine failures—disproportionate, that is, to the chance that you would ever experience a total power loss on one engine. All instructors know that placing emphasis on the negative aspects of a subject is a poor teaching technique, and it is with reluctance that they devote more time to the hazards of multi-engine flight than to its positive aspects. What they know, and what you should read into their instruction and into this text, is that multi-engine airplanes can be controlled when only one engine is running if the pilot knows what to do, how to do it, and why it is being done—and has the presence of mind to do the right thing when the situation demands it. When your friends show you statistics on multi-engine accidents, point out that there are no statistics on how many twins experienced problems but landed without incident.

When both engines are purring in sweet harmony, a twin doesn’t fly any differently than any sleek single-engine retractable. If the single-engine of that retractable quits, however, the failure does not create control problems. You have little choice but to find the safest, least expensive spot to put it down. A second engine provides you with options, depending on where you are when the failure occurs. Some wags have said that it takes you to the scene of the accident. Realistically, once you have gained control of the airplane after an engine failure, the odds are very much in your favor.

The FAA doesn’t require that a multi-engine airplane weighing less than 6,000 pounds be able to climb or even maintain altitude on one engine; its only requirement is that the plane be controllable as it gradually sinks earthward. When you hear the phrase “light twin,” remember that 6,000-pound limit. However, almost all light twins are able to climb at least minimally on one engine. The Champion Lancer, a fabric-covered, fixed-gear twin, is known for its inability to

maintain altitude when one of its little engines quits. Airplanes heavier than 6,000 pounds (or which stall at a speed higher than 61 knots) must demonstrate the ability to climb on one engine at 5,000 feet above sea level, and that means either more horsepower or turbocharging.

BEGINNING YOUR MULTI-ENGINE TRAINING

When you first learned to fly, your relationship with your instructor was clear-cut; the instructor took over control of the airplane whenever a situation began to deteriorate. You were a novice, your instructor was a professional, and “I’ve got it!” was your signal to let go of everything. When you begin your multi-engine instruction, the situation will change. You are now an experienced pilot, and until your instructor decides it is time to begin failing engines, he or she will place responsibility for normal operations in your hands. Unfortunately, the airplane doesn’t know this comfortable situation exists, and it may decide to test the reactions of the entire front-seat crew. From the first takeoff, then, there should be complete understanding of who is in charge of the airplane if something out of the ordinary occurs. There have been many incidents in which each pilot thought the other was in control, and just as many in which both pilots were trying to fly the airplane at the same time.

Instructional flight has the highest rate of accidents after engine failure, and for good reason. One proficient pilot can handle an engine-out emergency alone, and a crew of two with specific emergency duties assigned can handle a failed engine without it turning into an accident. With an instructor and multi-engine student occupying the front seats, however, confusion can result. The instructor wants to see how far into a situation the student can go without losing control, and the student feels that the instructor will bail him or her out before things get dicey.

Each occupant of a pilot seat should have a clear understanding of his or her responsibilities as the throttles are pushed forward. By now I hope that you are asking, “What is so different about having one of the engines fail on a multi-engine airplane?” The answer lies in some aerodynamic laws you are already aware of.

WHAT HAPPENS WHEN AN ENGINE FAILS

When you practiced steep turns as a student pilot, you learned that if one wing is moving faster than the other, the lift imbalance will cause the airplane to roll toward the slower wing; you called it “overbanking tendency” then. You also learned about P-factor, the force created by the descending propeller blade that causes left-turning tendency in single-engine airplanes. Your instructor admonished you to use rudder when rolling into a turn to offset the drag created by a downward-deflected aileron. All of these elements will be present as we consider the effect of engine failure.

Basically, when an engine fails on a twin, its wing is no longer being pulled forward and the opposite wing begins to move faster; the resulting yaw develops a rolling moment toward the dead engine. P-factor comes into play as the pilot increases the pitch attitude to avoid losing altitude. Finally, the windmilling propeller on the ailing engine creates drag of much greater magnitude than a deflected aileron. Put all of these reactions together, and you can visualize why the airplane rolls and turns toward the failed engine, and why, if the pilot does not act quickly and correctly, the airplane might hit the ground in a steep bank or inverted. It doesn’t have to happen, and your training will give you confidence in your ability to handle such an emergency if your skills are kept sharp. In later chapters, we will go into detail about what to do and why you do it.

MULTI-ENGINE AERODYNAMICS

Figure 1-3 shows the forces at work when both engines are operating. There is no imbalance in either thrust or lift. The propellers on both engines rotate clockwise as seen from the cockpit, so the descending blades on the right side of the propeller discs are doing most of the work. However, note that the left engine’s descending blade is much closer to the centerline of the fuselage than is the descending blade on the right engine. If the right engine fails, the yawing force exerted by the left engine’s P-factor will be relatively small, as indicated by the little arrow. If the left engine fails, however, the force exerted by the right engine’s descending blade will be farther from the centerline and the yawing force will be much greater; the large arrow emphasizes the difference. The left engine is called the critical

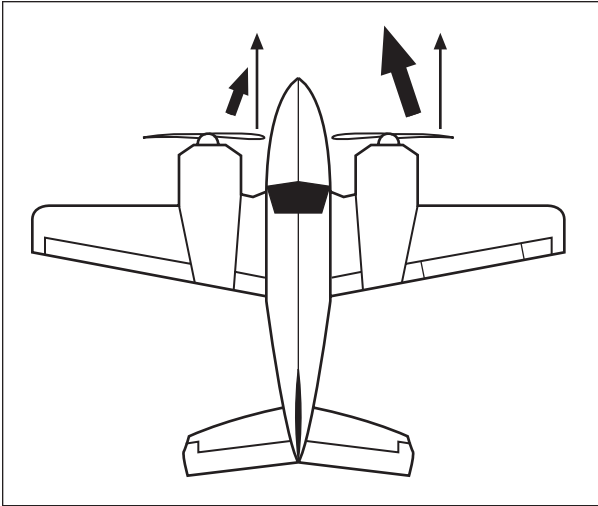

Figure 1-3. Yaw force due to P-factor

engine; its failure would create the most control problems for the pilot.

The propellers on twins certificated overseas usually rotate counterclockwise as seen from the pilot seat, so the situation is reversed—for those airplanes, the right engine is the critical engine.

Many modern multi-engine airplanes have counter-rotating propellers—the right engine's propeller rotates counterclockwise, so that the descending blades of both engines are equidistant from the centerline and P-factor cancels out. There is no critical engine. This reduces, but does not eliminate, the problems associated with controlling the airplane on one engine.

To illustrate how an engine failure causes a yaw and roll toward the dead engine, first look at the top of Figure 1-4 in which the thrust developed by the engines is represented by airplane tugs. (Since airplane tugs can't get much traction when airborne, the airplane in the illustration is on the ramp and cannot be banked.) The forces on the wings are balanced, and the airplane moves forward in a straight line. However, if one tug loses a wheel and stops pulling, the force of the other tug pulling its wing forward will cause the airplane to turn toward the dead tug. If a third tug rushes to the rescue and pushes on the good tug side of the fuselage near the tail, the turning motion can be arrested. Imagine all of this activity taking place in the dead of winter with the ramp covered with ice; the airplane will continue to move straight down the taxiway, although its nose is pointed to the right of the direction of travel. This is the result of the force

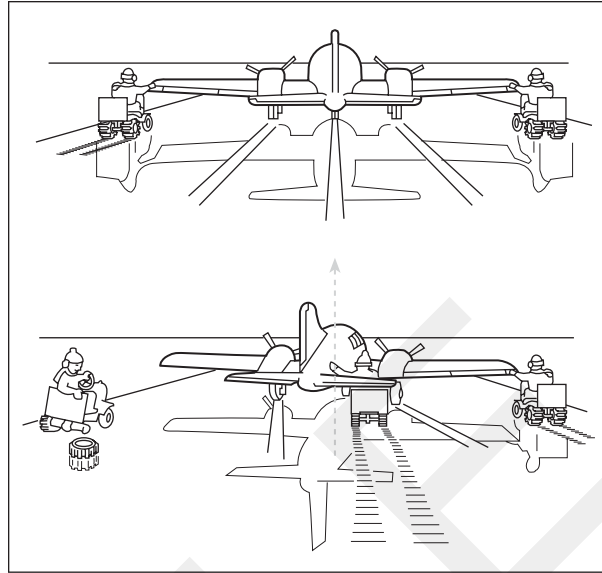

Figure 1-4. Zero sideslip without banking

exerted by the tug on the right wing, and the push on the tail's right side provided by the third tug's driver.

Replace the two wing-tip tugs with engine thrust and the fuselage tug with a fully deflected rudder, and you can see why an airplane with one engine inoperative and its wings level is slipping toward the dead engine. The relative wind blows against the side of the fuselage and the resultant drag increase is significant. There is no way to bring the relative wind into alignment with the centerline of the fuselage as long as the wings are level.

Get the airplane airborne, however, and a new stabilizing force becomes available: the horizontal component of lift that is developed when the wings are banked. On the left side of Figure 1-5, control surface deflection replaces the forces exerted by the tugs in Figure 1-4, and the resultant motion is indicated by the arrows. When the wings are level, a vertical lift vector is developed, and the magnitude of that vector is equal to the weight of the airplane. As you begin to roll the airplane, the vertical lift vector shrinks (and you must increase the angle of attack to maintain altitude), and a horizontal lift component is developed which increases in proportion to the angle of bank. At a 90-degree bank angle, there would be no vertical lift vector and the airplane would fall out of the sky.

So much for reviewing turn dynamics. By banking toward the good engine (Figure 1-5, right side) you can develop a horizontal lift vector that will, in effect, provide a correcting force so the airplane will fly forward without any appreciable degree of sideslip.

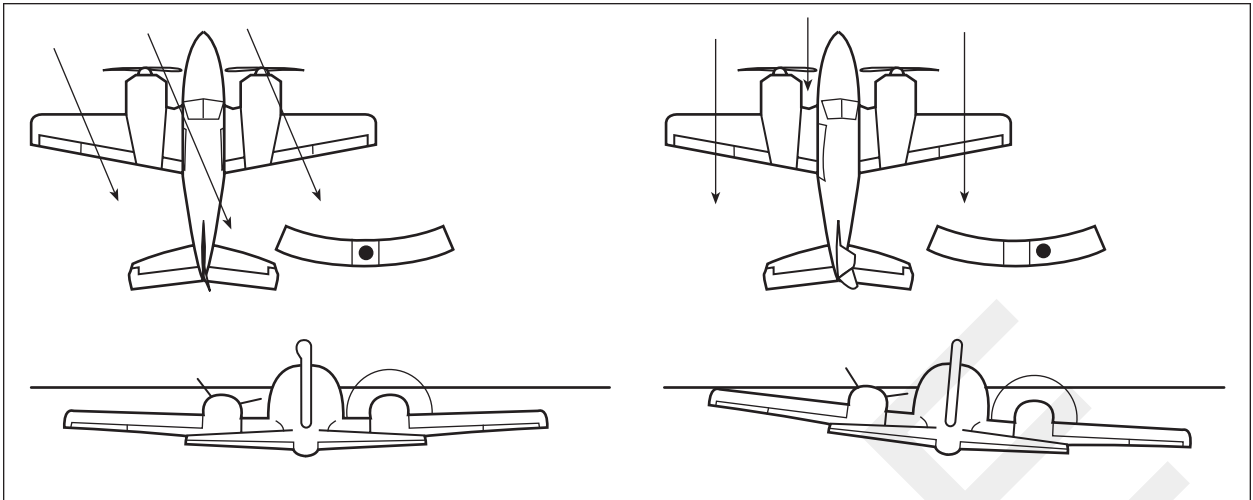

Figure 1-5. Horizontal component of lift provides force to correct sideslip

You could, theoretically, bank steeply enough that the horizontal component of force would make rudder deflection unnecessary. Of course, at liftoff and initial climb speeds, it is not possible to maintain altitude if you bank that steeply. Note the position of the ball on each side of Figure 1-5. With the wings level and the airplane slipping toward the dead engine, trimming the ball into the center is the wrong answer. FAA experiments have shown that a pilot can lose control of the airplane at airspeeds as much as 15 knots higher than the minimum control speed marked on the airspeed indicator if the wings are level with the ball centered. Minimum control speed (V_{MC}) will be discussed in detail in Chapter 3.

To achieve the book V_{MC} figure, you must establish a bank angle of at least 5 degrees toward the good engine and let the ball move about one-half diameter toward the good engine. In this situation, the ball acts as a bank indicator, not a slip/skid indicator. A 5-degree bank duplicates the conditions under which the manufacturer determined V_{MC} , and its intent is to help you regain control after an engine failure. The 5-degree figure does not apply in real life, however. Bank as much as you have to in order to avoid loss of control. As bank angle approaches 10 degrees, climb performance is adversely affected, though, so when you have the airplane under control, you can reduce the bank angle until the ball is deflected halfway out of the center for best performance. That lays the theoretical foundation for the actions you will take in an engine-out emergency. In later chapters, we will discuss just what you should do if an engine fails during

takeoff and initial climb, during cruise, or during the descent and approach to land.

Figure 1-6 illustrates the use of a yaw string, taped to the nose of the airplane and free to stream with the relative wind. The string streams toward the good engine side with the wings level, and becomes aligned with the longitudinal axis when the airplane is banked into the good engine, graphically illustrating zero sideslip.

The last few paragraphs have talked about bank angle. Go back to page 4 and note the words “fully deflected rudder.” Never fail to push the rudder on the good engine side all the way to the firewall; if you don’t stop the nose from yawing toward the dead engine it will be impossible to control the resulting roll.

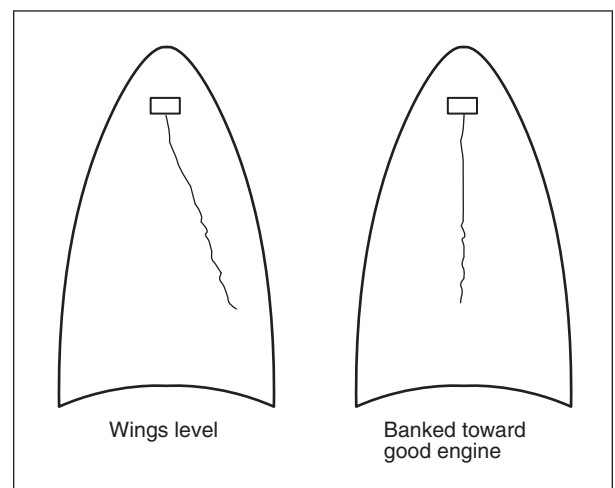

Figure 1-6. Yaw string

CENTERLINE THRUST

The obvious answer to the problems presented by off-center thrust is to place the engines on the airplane's centerline. This is just what Cessna did with the 336/337 Skymaster, which made its debut in 1964. The in-line twin served in Vietnam as the U. S. Air Force O-2. They were last produced in 1980, having failed to excite enough interest to sustain production.

The certificate of a pilot who takes the Multi-Engine Land practical test in a Skymaster will be endorsed "For Centerline Thrust Only." The newly minted twin pilot will have to be trained in and take another checkride in an airplane with wing-mounted engines to have this restriction removed.

From the pilot's perspective, a Skymaster with both engines running flies like a very capable single-engine airplane. Performance suffers drastically when either engine fails, of course, but the airplane climbs better with only the rear engine running than it does on the front engine alone. This is because the discharge

airflow from the front engine is energized as it passes through the rotating rear propeller and hugs the fuselage. With the rear engine feathered, discharge air from the front propeller detaches from the fuselage, creating drag and reducing climb performance.

Unlike most other twins, retracting the landing gear is not an immediate-action checklist item when an engine fails. Putting the gear switch in the "retract" position causes the gear doors (which are closed when the gear is down) to open while the gear is in transit, exposing large drag-producing openings.

Skymaster pilots start the rear engine first, and let its instrument indications stabilize before starting the front engine. If the rear engine should shut down after the front engine is started, the pilot has nothing but instrument indications to rely on as a warning; there have been incidents/accidents when the pilot took off on the front engine only, unaware that the rear engine had failed.

CHAPTER 1

Review Questions

1. What distinguishes a “light” twin from a “heavy” twin?
A—A light twin weighs less than 6,000 pounds.
B—A light twin’s V_{SO} is less than 61 knots.
C—Both A and B.
2. On a conventional twin, when an engine fails the airplane yaws toward
A—the good engine.
B—the critical engine.
C—the failed engine.
3. If an airplane weighs less than 6,000 pounds and has a V_{SO} of less than 60 knots, the manufacturer must demonstrate that the airplane is able to climb at least _____ feet per minute on a standard day at sea level with one propeller feathered.
A—50
B—100
C—There is no minimum climb requirement.
4. If an airplane cannot climb with one propeller feathered, the reason is that
A—drag is greater than lift.
B—drag is greater than thrust.
C—lift is greater than thrust.
5. Which statement concerning drag is true?
A—Parasitic drag is greatest at low speed.
B—Parasitic drag increases as speed increases.
C—The airplane is most efficient when parasitic and induced drag are equal.
6. In a high-power, low-speed situation such as initial climb, a propeller’s descending blade
A—creates more torque than the ascending blade.
B—creates more thrust than the ascending blade.
C—is further from the centerline than the ascending blade.
7. The propeller of a failed engine creates the least drag when it is
A—feathered.
B—windmilling.
C—stopped.
8. On an airplane with counter-rotating propellers, the _____ engine is the critical engine.
A—right
B—left
C—Neither; there is no critical engine.
9. How can a pilot whose multi-engine rating is limited to centerline thrust act as pilot-in-command of an airplane with wing-mounted engines?
10. When an engine fails on a twin-engine airplane, how much climb performance is lost?
A—80 percent
B—50 percent
C—20 percent

THE COMPLETE MULTI-ENGINE PILOT

Pilots learning multi-engine flying have relied on this essential book for more than 20 years. Learn fundamentals of flying multi-engine airplanes and the aerodynamic laws that govern multi-engine flight under Bob Gardner's experienced and energetic tutoring. This fifth edition includes a new chapter on energy management and information on both obtaining the multi-engine rating and checking out in a new twin. An integrated flight and ground syllabus details the program for the rating and provides a sample written test, typical of the one used for new-aircraft checkouts. Also contains a complete library of FAA source material on multi-engine flight subjects. The Complete Pilot series is designed for use in flight schools, for home study, and as a base for student kits.

FIFTH EDITION Bob Gardner

From the Foreword by Barry Schiff:

"By studying the principles Bob Gardner so eloquently discusses—and simplifies!—the challenging task of becoming a proficient and knowledgeable multi-engine pilot will become easier and more understandable."

Also in The Complete Pilot Series:

The Complete Private Pilot
The Complete Private Pilot Syllabus
The Complete Advanced Pilot
The Complete Remote Pilot



Aviation Supplies & Academics, Inc.
7005 132nd Place SE
Newcastle, Washington 98059 USA
425-235-1500 | asa2fly.com

ASA-MPT-5

TRANSPORTATION USD \$24.95

ISBN 978-1-64425-195-9



9 781644 251959

52495 >